

P619-BS/ SS
60 cm Built-in fan oven

P629-BS/ SS & P639-BS/ SS
60cm Built-in multifunction oven.

INSTRUCTION MANUAL

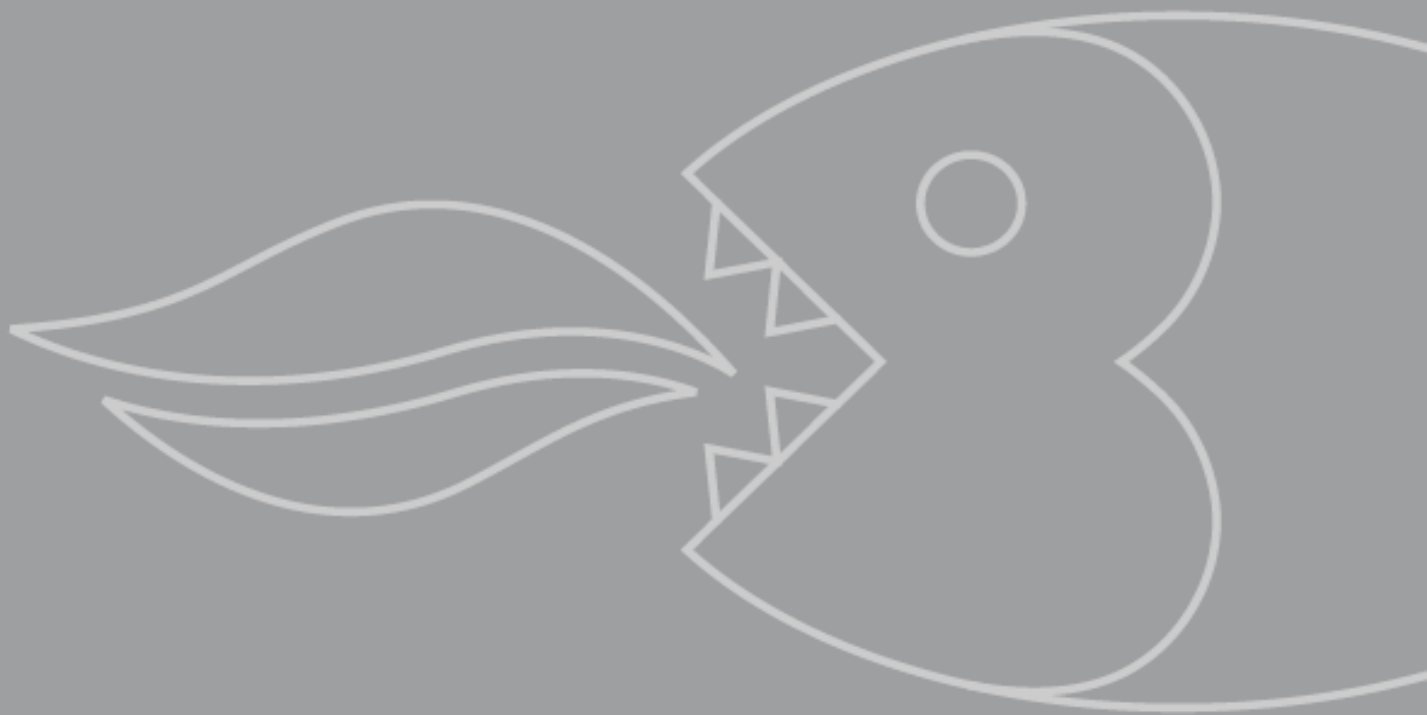

User Manual for your Baumatic

P619-BS/ SS 60 cm 4 Function fan oven
P629-BS/ SS 60 cm 7 Function multifunction oven
P639-BS/ SS 60 cm 9 Function multifunction oven



NOTE: This User Instruction Manual contains important information, including safety & installation points, which will enable you to get the most out of your appliance. Please keep it in a safe place so that it is easily available for future reference; for you or any person not familiar with the operation of the appliance.

GS 04/09/13

Contents

Environmental note	4
Important safety information	5 – 7
Specifications	8 - 14
P619-BS/ SS	8 - 9
P629-BS/ SS	9 - 10
P639-BS/ SS	10 - 11
Cooling fan	12
Control panel	13 - 14
Oven programmer/timer display	14
Setting and using the oven programmer/ timer	14 - 20
Selecting manual operation mode	14
Setting the time of day	14
The oven timer	14
Before first use	15
Setting the minute minder function	16
Setting the duration function	17
Setting the end cook function	18
Setting the start and end time function	19
Adjusting the audible signal	20
Selecting a cooking function and temperature	20 - 25
Selecting manual operation mode	20
Selecting an oven function	20
P619BS/SS oven functions	21
P629BS/SS oven functions	21 – 22
P639BS/SS oven functions	22 - 23
Thermostat control knob	23
Oven operating light	23
Cooking guidelines	24
Warnings	25
Shelf levels	25 - 26
Cleaning and maintenance	26 - 28
Removable oven roof liner (P629BS/SS and P639BS/SS only)	27
Replacing the oven bulb	27
Removing the oven door for cleaning	28
Removing the inner door glass for cleaning	29
Installation	30 - 33
Electrical connection	30
Installing the oven into the kitchen cabinet	31
Positioning the appliance	31
Ventilation requirements	32 - 33
My appliance isn't working correctly	33 -35
Baumatic consumables	36
Contact details	37

Environmental note

This appliance is marked according to the European directive 2002/96/EC on Waste electrical and Electronic Equipment (WEEE). By ensuring this product is disposed of correctly, you will help prevent potential negative consequences for the environment and human health, which could otherwise be caused by inappropriate waste handling of this product.

The symbol  on the product, or on the documents accompanying the product, indicates that this appliance may not be treated as household waste. Instead it shall be handed over to the applicable collection point for the recycling of electrical and electronic equipment.

Disposal must be carried out in accordance with local environmental regulations for waste disposal.

For more detailed information about treatment, recovery and recycling of this product, please contact your local city office, your household waste disposal service or the shop where you purchased the product.



- The packaging materials that Baumatic uses are environmentally friendly and can be recycled.
- Please discard all packaging material with due regard for the environment.

IMPORTANT SAFETY INFORMATION



Your safety is of the utmost importance to Baumatic. Please make sure that you read this instruction booklet **before** attempting to install or use the appliance. If you are unsure of any of the information contained in this booklet, please contact the Baumatic Advice Line.

General Information

- This appliance is designed for domestic household use and can be built into a standard kitchen cabinet or housing unit.
- **IMPORTANT:** *The adjacent furniture or housing and all materials used in the installation **must** be able to withstand a minimum temperature of 85°C above the ambient temperature of the room it is located in, whilst in use.*
- Certain types of vinyl or laminate kitchen furniture are particularly prone to heat damage or discolouration at temperatures below the guidelines given above.
- Any damage caused by the appliance being installed in contravention of this temperature limit, or by placing adjacent cabinet materials closer than 4mm to the appliance, **will be the liability of the owner.**
- The use of this appliance for any other purpose or in any other environment without the express agreement of Baumatic Ltd. will invalidate any warranty or liability claim.
- Your new appliance is guaranteed against electrical or mechanical defects, subject to certain exclusions that are noted in Baumatic's Conditions Of Guarantee. The foregoing does not affect your statutory rights.
- **Repairs may only be carried out by Baumatic service engineers or their authorised service agent.**

Warning and safety instructions

- This appliance complies with all current European safety legislation. Baumatic do wish to emphasise that this compliance does not remove the fact that the appliance surfaces **will become hot during use and retain heat after operation.**

- This appliance is not intended for use by persons (including children) with reduced physical, sensory or mental capabilities, or lack of experience and knowledge, unless they have been given supervision or instruction concerning use of the appliance by a person responsible for their safety.

Child Safety

- Baumatic strongly recommend that babies and young children are prevented from being near to the appliance and not allowed to touch the appliance **at any time**.
- If it is necessary for younger family members to be in the kitchen, please ensure that they are kept under close supervision at all times.

General Safety

- **Do not** place heavy objects on the oven door or lean on the oven door when it is open, as this can cause damage to the oven door hinges.
- **Do not** leave heated oil or fat unattended, as this is a fire risk.
- **Do not** place pans or baking trays directly on the base of the oven cavity, or line it with aluminium foil.
- **Do not** allow electrical fittings or cables to come into contact with areas on the appliance that get hot.
- **Do not** use the appliance to heat the room it is located in or to dry clothing.
- **Do not** install the appliance next to curtains or soft furnishings.
- **Do not** attempt to lift or move cooking appliances by using the oven door or handle, as this may cause damage to the appliance or result in injury to the person lifting the appliance.

Cleaning

- Cleaning of the oven should be carried out on a regular basis.
- Great care should be taken whilst using this appliance and when following the cleaning procedure.
- **IMPORTANT:** *The appliance must be disconnected from the mains before following the cleaning procedure.*

Installation



This appliance must be correctly installed by a suitably qualified person, strictly in accordance with the manufacturer's instructions.

- ***Baumatic Ltd. declines any responsibility for injury or damage, to person or property, as a result of improper use or installation of this appliance.***
- Heat, steam and moisture will be created during use of the appliance, take care to avoid injury and ensure that the room is adequately ventilated. If the appliance is going to be used for prolonged periods of time, then additional ventilation may be required.
- Please consult with your qualified installer if you are in any doubt about the amount of ventilation that you will require.

Declaration of conformity

This appliance complies with the following European Directives:

- 2006/95/EC regarding "low voltage"
- 2004/108/EC regarding "electromagnetic disturbances"
- Regulation (EC) N° 1935/2004 regarding "materials in contact with food"
- The above directives comply with 93/68/EEC regarding CE marking.
- The manufacturer declares that the oven is built using certified materials and requires the appliance to be installed in accordance with the standards currently in force. This appliance must be used by a trained person for domestic purposes only.

Specifications

P619BS/ SS

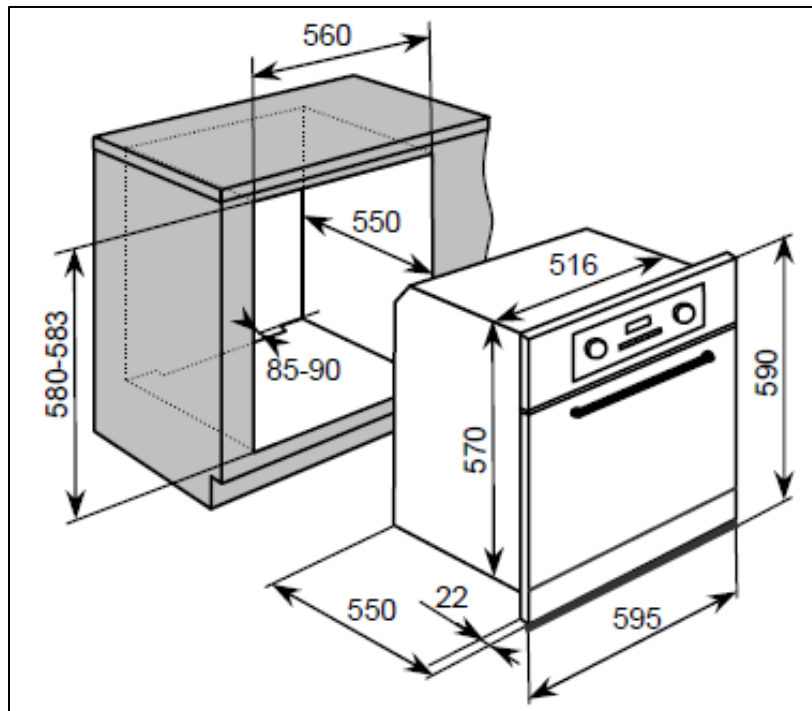

Product Dimensions

Height: 590 mm
Width: 595 mm
Depth: 550 mm

Aperture dimensions

Height: 580 – 583 mm
Width: 560 mm
Depth: 550 mm

Product specifications

- 4 oven functions
- Energy efficiency class: A
- Gross oven capacity: 59 litres
- Net oven capacity: 50 litres
- Oven light
- LED full programmer
- Cooling fan
- Thermostatically controlled grill
- Triple-glazed removable door
- Removable inner door glass
- Mark resistant coating

Standard accessories

- Enamelled baking tray with handle
- Safety shelf
- Trivet
- Removable side racks

Optional extras

- TEL2KIT Telescopic runners kit
- SCL7KIT Stay-clean liners kit
- BPS2 Pizza stone

Electrical details

Rated Voltage:	220 - 240 Vac 50 Hz
Supply Connection:	13A (double pole switched fused outlet with 3mm contact gap)
Max Rated Inputs:	2.35 kW
Mains Supply Lead:	3 x 1.5mm ²
Oven Light Bulb:	25 W/300°C screw type pygmy

P629BS/ SS

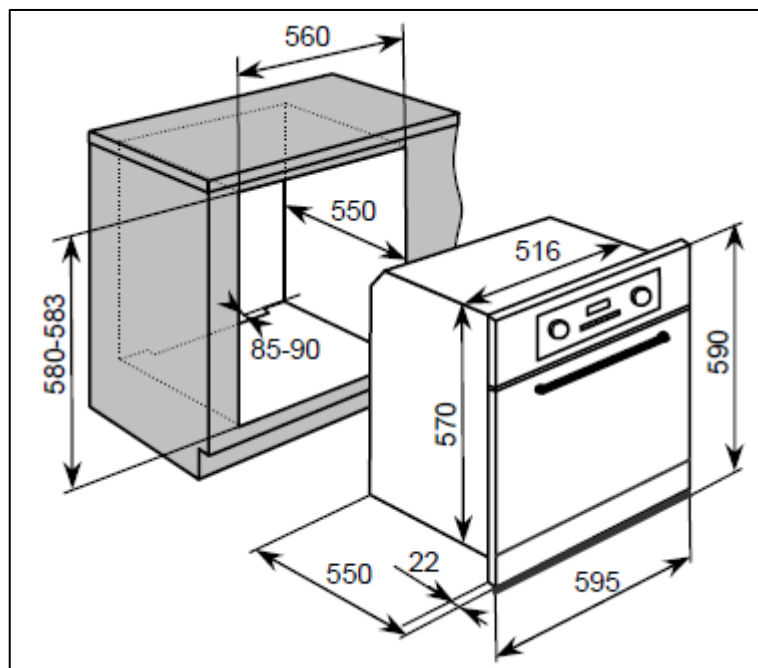

Product Dimensions

Height:	590 mm
Width:	595 mm
Depth:	550 mm

Aperture dimensions

Height:	580 – 583 mm
Width:	560 mm
Depth:	550 mm

Product specifications

- 7 oven functions
- Energy efficiency class: A
- Gross oven capacity: 59 litres
- Net oven capacity: 50 litres
- Oven light
- LED full programmer

- Cooling fan
- Thermostatically controlled grill
- Triple-glazed removable door
- Removable inner door glass
- Mark resistant coating

Standard accessories

- Enamelled baking tray with handle
- 2 x Safety shelves
- Trivet
- Removable side racks
- Removable roof liner
- Telescopic runners- 1 level

Optional extras

- SCL7KIT Stay-clean liners kit
- BPS2 Pizza stone

Electrical details

Rated Voltage:	220 - 240 Vac 50 Hz
Supply Connection:	13A (double pole switched fused outlet with 3mm contact gap)
Max Rated Inputs:	2.40 kW
Mains Supply Lead:	3 x 1.5mm ²
Oven Light Bulb:	25 W/300°C screw type pygmy

P639 BS/ SS

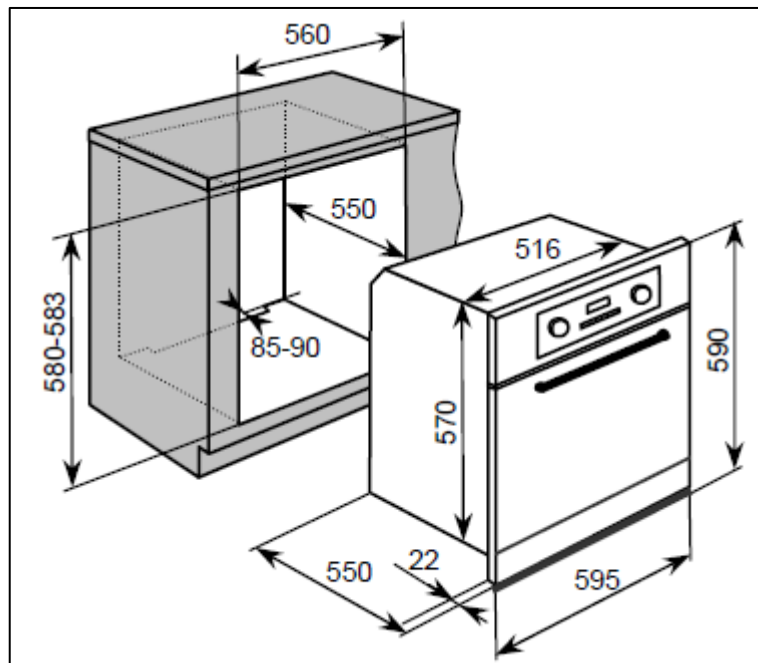

Product Dimensions

Height: 590 mm
Width: 595 mm
Depth: 550 mm

Aperture dimensions

Height: 580 – 583 mm
Width: 560 mm
Depth: 550 mm

Product specifications

- 9 oven functions
- Energy efficiency class: A
- Gross oven capacity: 59 litres
- Net oven capacity: 50 litres
- Oven light
- LED full programmer
- Cooling fan
- Thermostatically controlled grill
- Triple-glazed removable door
- Removable inner door glass
- Mark resistant coating

Standard accessories

- Enamelled baking tray with handle
- 2 x Safety shelves
- Trivet
- Deep baking tray
- Removable side racks
- Removable roof liner
- BPS2 Pizza stone
- Telescopic runners – 2 levels

Optional extras

- SCL7KIT Stay-clean liners kit

Electrical details

Rated Voltage:	220 - 240 Vac 50 Hz
Supply Connection:	16A (double pole switched fused outlet with 3mm contact gap)
Max Rated Inputs:	3.35 kW
Mains Supply Lead:	3 x 1.5mm ²
Oven Light Bulb:	25 W/300°C screw type pygmy

Cooling fan

- A tangential cooling fan is fitted inside of these appliances, to make the internal temperature of the oven stable and the external surface temperature lower.
- After you have finished cooking and switched off the oven, the cooling fan will continue to run for a period of time afterwards. The length of time will depend on how long the oven has been switched on for and at how high a temperature.

For future reference please record the following information which can be found on the rating plate and the date of purchase which can be found on your sales invoice. The rating plate for your oven can be located by opening the oven door and looking on the right hand side of the oven chassis.

Model Number

Serial Number

Date of Purchase

Control Panel

P619 BS/ SS

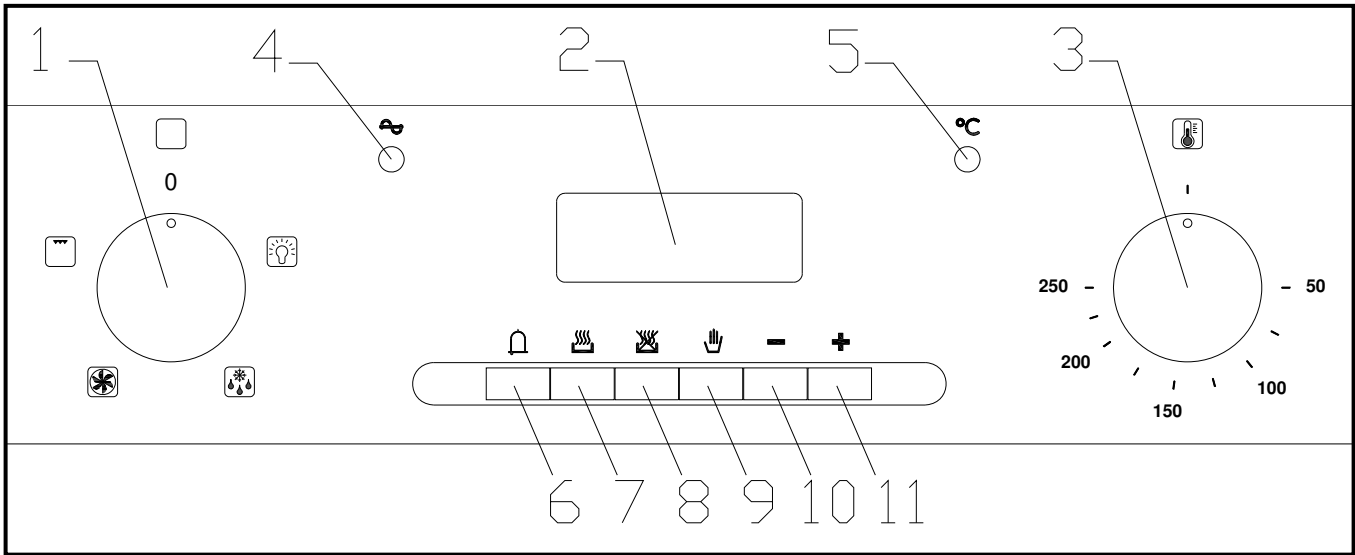

P629 BS/ SS

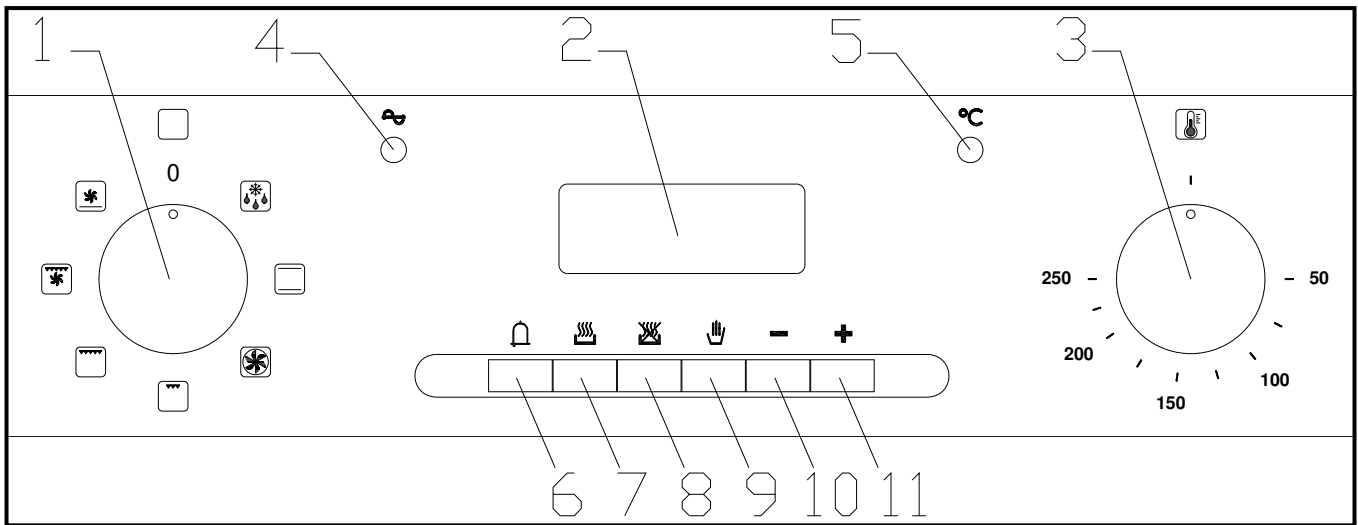

P639 BS/ SS

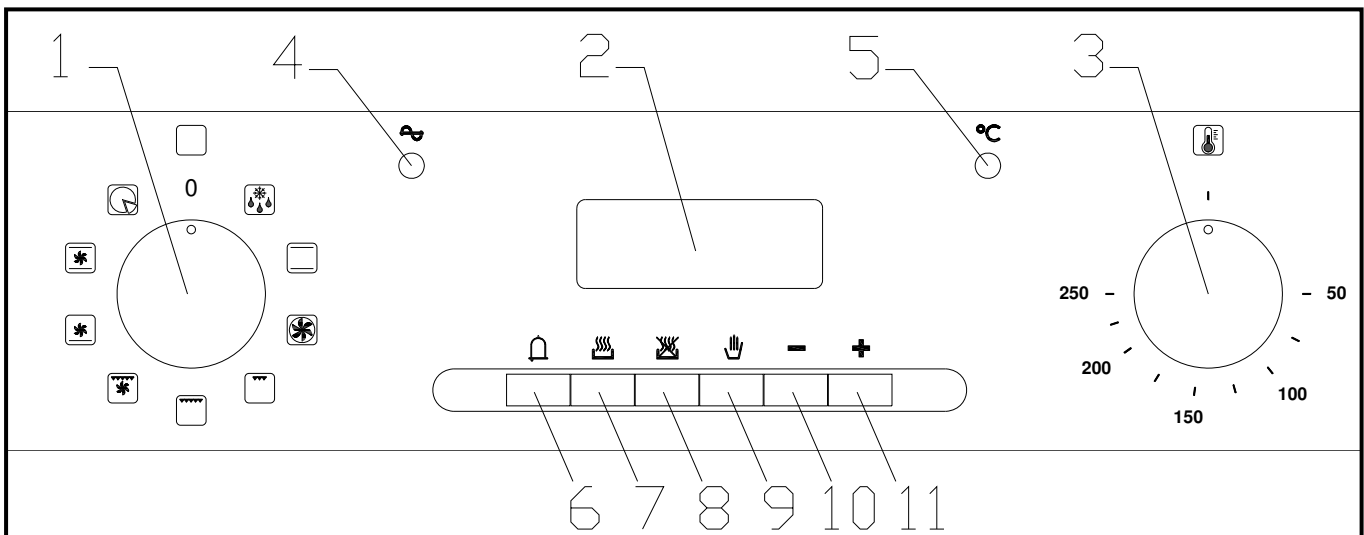

- 1) Oven function selector knob
- 2) LED display
- 3) Thermostat control knob
- 4) Power indicator light
- 5) Oven operating light
- 6) Timer minute minder button
- 7) Timer duration button
- 8) Timer end cook button
- 9) Timer manual operation button
- 10) Timer minus button
- 11) Timer plus button

Oven programmer/ timer display

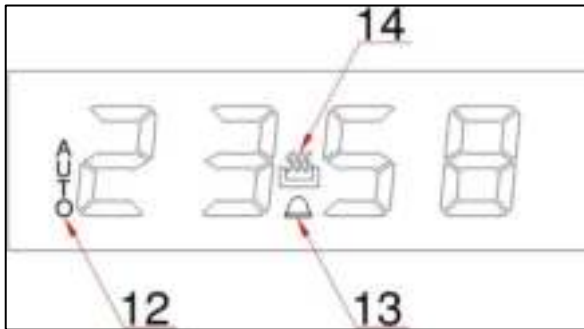

- 12) Auto function symbol
- 13) Minute minder symbol
- 14) Manual operation symbol.

Setting and using the oven programmer/ timer

Selecting manual operation mode

After your appliance is connected to your mains supply for the first time, the numbers on the timer display will flash. Before you can select a cooking function or set a temperature, you must set the appliance into “manual operation” mode.

- To select manual operation mode, press the manual operation button (9) on the control panel.

Setting the time of day

After setting your oven for manual operation, you should also set the time of day.

- After pressing the manual operation button (9), use the minus button (10) and plus button (11) to adjust the time that appears in the display. After getting the display to the correct time, release the minus and plus buttons. After a few seconds the time will fix in the display and you will be able to use your oven.

The oven timer

- Only the minute minder can be used with the defrost oven function. None of the other timer modes will work with the defrost function.

Before first use

- To remove any residue from the oven that may have been left from the manufacturing process, you should select the fan oven function and set the thermostat to its maximum temperature setting.
- It is perfectly normal for a smell to be produced during this process.
- You should make sure that any windows in the room are left open during this process.
- It is advisable for you not to remain in the room whilst the burning off process is taking place.
- You should leave the oven on maximum setting for 30 – 40 minutes.
- After the oven cavity has cooled, it should then be cleaned with warm soapy water, using either a sponge or soft cloth. No abrasive cleaners should be used.
- Outer parts of the oven should be cleaned with warm soapy water, using either a sponge or soft cloth. No abrasive cleaners should be used.
- We would recommend that an appropriate stainless steel cleaner and polish is regularly used on the stainless steel surfaces of this appliance.

Setting the minute minder function

You are able to set the minute minder at any time, regardless of whether an oven function has been selected. You can set a period of time using the minute minder function and an alarm will sound when that period of time has elapsed.

- Press the minute minder button **(6)**, the display will show a value of 00:00. Set the period of time that you wish the minute minder to countdown for, by using the minus **(10)** and plus **(11)** buttons.
- Once the display has got to your desired countdown time, let go of the minus and plus buttons. The minute minder symbol **(13)** will appear on the timer display.
- Once a countdown time has been set, it is possible to shorten or lengthen the time by using the minus or plus buttons.
- An alarm will sound when the countdown time has elapsed. The alarm can be silenced by pressing the minute minder button.
- ***Important:*** *The oven will continue to heat once the alarm has been silenced. If you have finished cooking, then you should turn the oven function selector and thermostat control knob to 0.*

Setting the duration function

This function will allow you to set a countdown time similar to the minute minder function. However the oven will no longer continue to heat, once the countdown period has elapsed.

- Use the thermostat control knob (3) to set the temperature that you require. The manual operation symbol (14) will appear on the display.
- Use the oven function selector knob (1) to select the mode of cooking that you require.
- It is then possible to set the duration of the cooking time that you require.
- Press the duration button (7) and the display will show a value of 00:00. Set the period of time that you wish the duration function to countdown for, by using the minus (10) and plus (11) buttons.
- Once the display has got to your desired countdown time, let go of the minus and plus buttons. The countdown will start immediately and the word AUTO will appear on the timer display.
- Once a countdown time has been set, it is possible to shorten or lengthen the time by using the minus or plus buttons.
- An alarm will sound when the countdown time has elapsed and the oven will switch off. The word AUTO will flash and the heating symbol will disappear. The alarm can be silenced by pressing the duration button.
- You will need to return the oven to manual operation mode, once the duration function has been used. To do this you should press the “manual operation” button, the word AUTO will disappear from the display and the manual operation symbol will appear instead.
- ***Important:*** *If you do not turn the thermostat control knob and oven function selector knob to 0, then the appliance will continue to operate as soon as you press the manual operation button.*

Setting the end cook function

This function is similar to the duration function, however instead of selecting a period of time that you wish the oven to switch off after. You select the time of day that you wish the oven to switch off at.

- Use the thermostat control knob (3) to set the temperature that you require. The manual operation symbol (14) will appear on the display.
- Use the oven function selector knob (1) to select the mode of cooking that you require.
- Press the end cook button (8) and the display will show the current time of day. Set the time of day that you wish the oven to stop cooking at by using the minus (10) and plus (11) buttons. The timer will calculate how long the cooking time will be, based on the time of day that you have selected and show it on the display.
- Once the display has got to the time of day that you want the oven to stop cooking at, let go of the minus and plus buttons. The countdown will start immediately and the word AUTO will appear on the timer display.
- When the time is set, it can be modified by pressing the minus and plus buttons.
- When the time of day reaches the end of cooking time that you set, the oven will switch off and an alarm will sound. The word AUTO will flash and the heating symbol will disappear. The alarm can be silenced by pressing the “end cook” button.
- You will need to return the oven to manual operation mode, once the end cook function has been used. To do this you should press the manual operation button, the word AUTO will disappear from the display and the manual operation symbol will appear instead.
- ***Important:*** *If you do not turn the thermostat control knob and oven function selector knob to 0, then the appliance will continue to operate as soon as you press the “manual operation” button.*

Setting the start and end time function

This function will allow you to set a time in the future that the oven switches on at and a time that the oven will switch off at.

- Use the thermostat control knob **(3)** to set the temperature that you require. The manual operation symbol **(14)** will appear on the display.
- Use the oven function selector knob **(1)** to select the mode of cooking that you require.
- Press the duration button **(7)** and the display will show a value of 00:00. Set the period of time that you wish to cook for, by using the minus **(10)** and plus **(11)** buttons. The word AUTO will appear on the timer display.
- ***Immediately*** press the end cook button **(8)** and the timer display will show a calculated end of cooking time. Set the time of day that you want the oven to switch off at, using the minus and plus buttons.
- The oven will calculate what time it needs to switch on at, so that your food will cook for the length of time that you selected. It will automatically switch itself on, once it reaches the time of day that it has calculated.
- When the time of day reaches the end of cooking time that you set, the oven will switch off and an alarm will sound. The word AUTO will flash and the heating symbol will disappear. The alarm can be silenced by pressing the end cook or duration button.
- You will need to return the oven to manual operation mode, once the start and end time function has been used. To do this you should press the manual operation button, the word AUTO will disappear from the display and the manual operation symbol will appear instead.
- ***Important:*** *If you do not turn the thermostat control knob and oven function selector knob to 0, then the appliance will continue to operate as soon as you press the manual operation button.*

Adjusting the audible signal

- The audible signal has three different settings, low, medium and high.
- To adjust the level of the audible signal, make sure that the timer is in manual mode. Then press and hold the minus button and you will hear the current level that is set.
- Press the minus button again and the audible signal will adjust to the next level.
- When the required level of audible signal is reached, release the minus button and it will be set.

Selecting a cooking function and temperature

Selecting manual operation mode

After your appliance is connected to your mains supply for the first time, the numbers on the timer display will flash. Before you can select a cooking function or set a temperature, you must set the appliance into “manual operation” mode.

- To select manual operation mode, press the manual operation button (9) on the control panel.

Selecting an oven function

P619BS/ SS

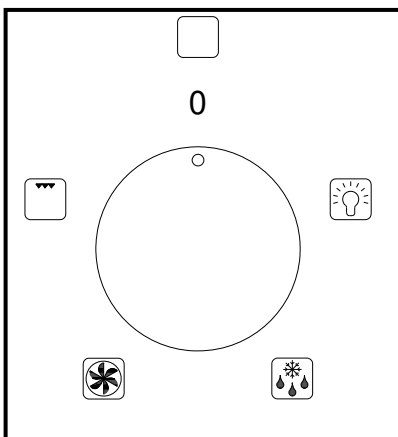

P629BS/ SS

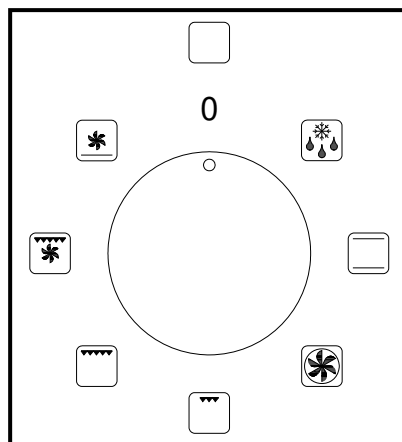

P639BS/ SS

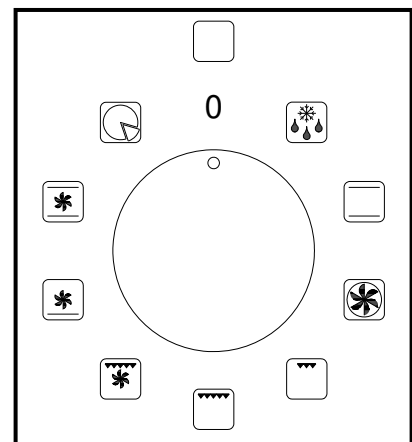

- The oven function selector knob should be used to select the particular mode of cooking that you require. The appliance will utilise different elements within the oven cavity, depending on the oven function that you select. When a function is selected, the power indicator light will come on.

P619BS/ SS oven functions



LIGHT MODE: Separate light control which allows the oven light to be switched on, even when the oven is not heating.

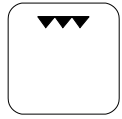

GRILL MODE: This method of cooking utilises the inner sections of the top element, which directs heat downwards onto the food. This function is suitable for grilling portions of bacon, toast and meat etc.



FAN OVEN: This method of cooking uses the circular element while the heat is distributed by the fan. This results in a faster and more economical cooking process. The fan oven allows food to be cooked simultaneously on different shelves, preventing the transmission of smells and tastes from one dish on to another.



DEFROST MODE: The fan runs without heat to reduce the defrosting time of frozen foods. The time required to defrost the food will depend on the room temperature, the quantity and type of food. Always check food packaging for the defrosting instructions.

P629BS/ SS oven functions

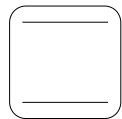

CONVENTIONAL OVEN (top and lower element): This method of cooking provides traditional cooking, with heat from the top and lower elements. This function is suitable for roasting and baking on one shelf only.

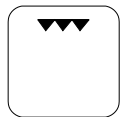

GRILL MODE: This method of cooking utilises the inner sections of the top element, which directs heat downwards onto the food. This function is suitable for grilling portions of bacon, toast and meat etc.

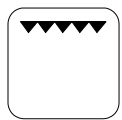

FULL GRILL: This method of cooking utilises the inner and outer parts of the top element, which directs heat downwards onto the food. This function is suitable for grilling medium or large portions of sausages, bacon, steaks, fish etc.



FAN OVEN: This method of cooking uses the circular element while the heat is distributed by the fan. This results in a faster and more economical cooking process. The fan oven allows food to be cooked simultaneously on different shelves, preventing the transmission of smells and tastes from one dish on to another.



FAN AND LOWER ELEMENT: This method of cooking utilises the bottom element in conjunction with the fan, which helps to circulate the heat. This function is suitable for sterilizing and preserving jars.



FAN AND GRILL: This method of cooking utilises the top element in conjunction with the fan, which helps to provide a quick circulation of heat. This function is suitable where quick browning is required and “sealing” the juices in, such as steaks, hamburgers, some vegetables etc.



DEFROST MODE: The fan runs without heat to reduce the defrosting time of frozen foods. The time required to defrost the food will depend on the room temperature, the quantity and type of food. Always check food packaging for the defrosting instructions.

P639BS/ SS oven functions

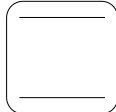

CONVENTIONAL OVEN (top and lower element): This method of cooking provides traditional cooking, with heat from the top and lower elements. This function is suitable for roasting and baking on one shelf only.

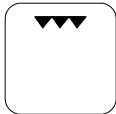

GRILL MODE: This method of cooking utilises the inner sections of the top element, which directs heat downwards onto the food. This function is suitable for grilling portions of bacon, toast and meat etc.

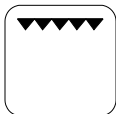

FULL GRILL: This method of cooking utilises the inner and outer parts of the top element, which directs heat downwards onto the food. This function is suitable for grilling medium or large portions of sausages, bacon, steaks, fish etc.



FAN OVEN: This method of cooking uses the circular element while the heat is distributed by the fan. This results in a faster and more economical cooking process. The fan oven allows food to be cooked simultaneously on different shelves, preventing the transmission of smells and tastes from one dish on to another.

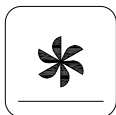

FAN AND LOWER ELEMENT: This method of cooking utilises the bottom element in conjunction with the fan, which helps to circulate the heat. This function is suitable for sterilizing and preserving jars.



CONVECTION OVEN AND FAN: This method of cooking provides traditional cooking with heat from the top and the lower element, it also utilises the circulation fan. This ensures a fast and even distribution of the heat. Suitable for light and delicate baking, such as pastries.



FAN AND GRILL: This method of cooking utilises the top element in conjunction with the fan, which helps to provide a quick circulation of heat. This function is suitable where quick browning is required and “sealing” the juices in, such as steaks, hamburgers, some vegetables etc.



PIZZA MODE: This method of cooking uses the lower and circular element while the heat is distributed by the fan reproducing the same conditions of traditional clay wood-fire stoves.



DEFROST MODE: The fan runs without heat to reduce the defrosting time of frozen foods. The time required to defrost the food will depend on the room temperature, the quantity and type of food. Always check food packaging for the defrosting instructions.

Thermostat control knob

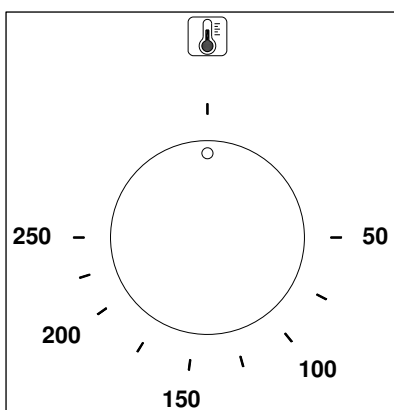

The oven thermostat control knob sets the required temperature of the oven. It is possible to regulate the temperature within a range of 50 - 250°C.

Oven operating light

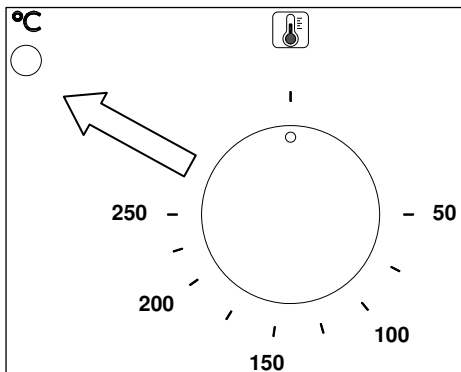

This light will come on to indicate that the oven's heating elements are in operation. The light will turn off when the temperature set on the thermostat control knob has been reached. It will cycle on and off throughout the cooking time.

You should not place food inside the cavity, until the correct cooking temperature has been reached.

Cooking guidelines

- Please refer to the information given on food packaging for guidance on cooking temperatures and times. Once familiar with the performance of your appliance, temperatures and times can be varied to suit personal preference.
- If you are using the fan oven function, then you should follow the information given on the food packaging for this particular mode of cooking.
- You should pre-heat the oven and not place food inside of it until the oven operating light has gone off. You can choose not to pre-heat when using the fan oven mode; however you should extend the cooking time given on the food packaging by at least ten minutes.
- ***IMPORTANT:*** *You should pre-heat the oven if you are baking no matter what oven function you are using.*
- If there is no guidance given on the food packaging specifically for cooking in fan oven mode, you can generally reduce the cooking time and temperature by 10% from the information given for conventional oven cooking.
- Make sure that frozen foods are thoroughly thawed before cooking, unless the instructions on the food packaging advise that you can “cook from frozen”.
- Before cooking, check that any accessories that are not required are removed from the oven.
- Place cooking trays in the centre of the oven and leave gaps between the trays to allow air to circulate.
- Try to open the door as little as possible to view the dishes.
- The oven light will remain on during cooking.

Warnings

- Keep the oven door closed when using **any** of the cooking functions, **including** the grill functions.
- Do not use aluminium foil to cover the enamelled baking tray or heat items wrapped in aluminium foil under the grill. The high reflectivity of the foil could potentially damage the grill element.

- You should also never line the base of your oven with aluminium foil.
- During cooking, never place pans or cookware directly onto the bottom of your oven. They should always be placed on the shelves provided.
- The grill heating element and other internal components of the oven become extremely hot during operation, avoid touching them inadvertently when handling the food which you are grilling.
- **Important:** *Be careful when opening the door, to avoid contact with hot parts of the oven and steam.*
- The baking tray handle should only be used to reposition the drip tray and **NOT** for removing it from the oven cavity.
- The baking tray handle should not be left in position when the appliance is switched on.
- When removing the baking tray, you should **ALWAYS** use an oven glove.
- **Warning:** *Accessible parts may become hot during use. Young children should be kept well away from the oven when it is in use.*

Shelf levels

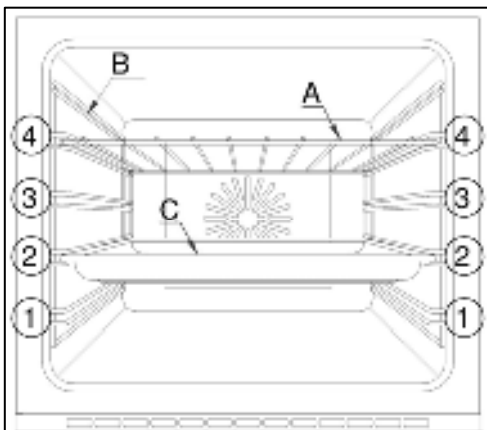

- Safety shelf (**A**)
 - Removable side racks, which allow you to cook on four different levels (**B**)
 - Enamelled baking tray (**C**)
- The numbers 1 – 4, indicate the different shelf positions that you can utilise within the oven.

Cleaning and maintenance



Cleaning operations must only be carried out when the oven is cool.

The appliance should be disconnected from your mains supply before commencing any cleaning process.

- The oven should be thoroughly cleaned before it is operated for the first time and after each use. This will avoid residual food stuffs becoming baked on the oven cavity. After residues have been baked on several times, they are far more difficult to remove.
- ***Never*** clean the oven surfaces by steam cleaning.
- The oven cavity should only be cleaned with warm soapy water, using either a sponge or soft cloth. No abrasive cleaners should be used.
- Any stains that may appear on the bottom of the oven will have originated from food splashes or spilt food, these splashes occur during the cooking process. These could possibly be a result of the food being cooked at an excessively high temperature or being placed in cookware that is too small.
- You should select a cooking temperature that is appropriate for the food that you are cooking. You should also ensure that the food is placed in an adequately sized dish and that you use the enamelled baking tray where appropriate.
- Outer parts of the oven should only be cleaned with warm soapy water, using either a sponge or soft cloth. No abrasive cleaners should be used.
- We would recommend that an appropriate stainless steel cleaner and polish is regularly used on the stainless steel surfaces of this appliance.
- If you use any form of oven cleaner on your appliance, then you must check with the manufacturer of the cleaner that it is suitable for use on your appliance.
- Do not use harsh or abrasive cleaners or sharp metal scrapers to clean the oven door glass since they can scratch the surface which may result in shattering.
- ***Any damage that is caused to the appliance by a cleaning product will not be fixed by Baumatic free of charge, even if the appliance is within the guarantee period.***

Removable oven roof liner (P629BS/ SS, P639BS/ SS only)

Your appliance is supplied with a roof liner, which should be slid over the top of the grill element.

- Once you have finished cooking, the liner should be removed and thoroughly cleaned after each use of the appliance.
- **Do not** allow fat and grease to build up on the oven liner, as this could cause a fire hazard.

Replacing the oven bulb



IMPORTANT: The oven must be disconnected from your mains supply before you attempt to either remove or replace the oven bulb.

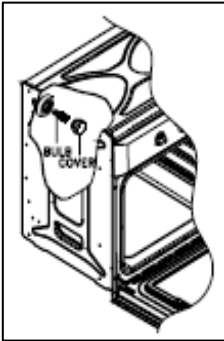

- Remove all oven shelves, the enamelled baking tray and the side rack that is on the same side as the oven light.
- Remove the light cover by turning it anti-clockwise.
- Unscrew the bulb clockwise and remove it from its holder.
- Replace the bulb with a 25 W/300°C, screw type pygmy.
- **Do not** use any other type of bulb.
- Place the lamp cover back into position.

Removing the oven door for cleaning

To facilitate the cleaning of the inside of the oven and the outer frame of the oven, the door can be removed as follows: -

- Open the oven door fully.

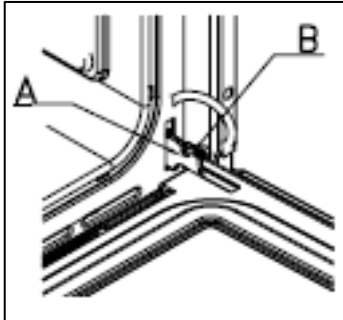

- The hinges (**A**) have two movable bolts on them (**B**).
- If you raise both of the movable bolts (**B**), then the hinges (**A**) are released from the oven housing.
- You should grip the sides of the door at the centre and then incline it slightly towards the oven cavity and then pull it gently away from the oven cavity. **WARNING- Care should be taken as the inner edges of the door may be sharp.**
- **IMPORTANT:** You should make sure that the door is supported at all times and that you place the door on some padded material whilst cleaning it.
- The oven door and door glass should only be cleaned using a damp cloth and a small amount of detergent. The cloth **MUST NOT** have come into contact with any form of cleaning product or chemical previously.
- To refit the door you should slide the hinges back into their slots and open the door fully.
- **IMPORTANT:** The movable bolts (**B**) must be closed back into their original positions before closing the door.



- **Take care not to dislodge the hinge locking system when removing the door, as the hinge mechanism has a strong spring.**
- **Do not immerse the door in water at any time.**

Removing the inner door glass for cleaning

- Do not use any abrasive cleaner that could cause damage.
- Remember that if the surface of the glass panel becomes scratched, this could lead to a dangerous failure.
- To facilitate cleaning, the inner door glass can be lifted out.

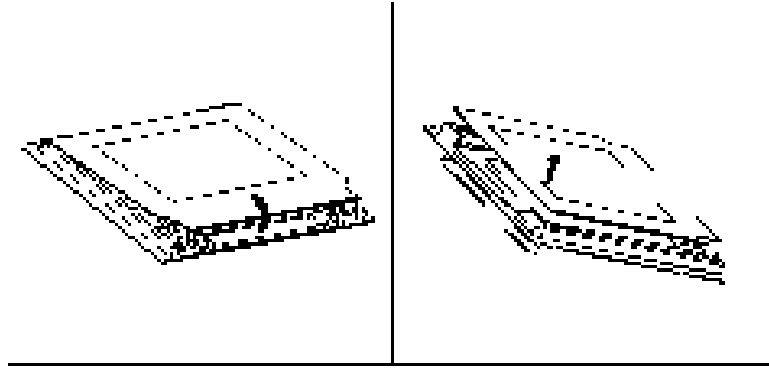

- Grip the top and the bottom of the inner door glass panel.
- Gently pull the **bottom** of the inner door glass panel upwards.

Do not raise the panel more than 35° as it can damage the securing clips.

- The securing clips at the top and bottom of the glass panel will pop out and the glass panel will be free to remove.

If the top securing clips do not pop out when pulling the bottom of the glass panel upwards, then pull the top of the glass panel upwards until the top also pops out.

- After cleaning, insert the glass panel correctly back into the door in the reverse order. Ensure the securing clips slot back into place and the glass panel locks into place securely.

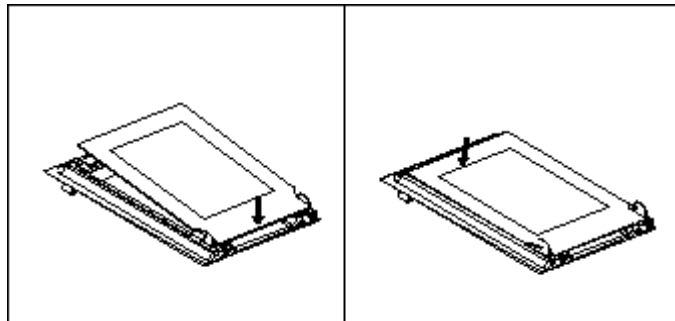

IMPORTANT: Remember where the panel of glass is removed from so you can reassemble the door correctly. Do not mix the glasses up or rearrange the order.

INSTALLATION



The installation must be carried out by a suitably qualified person, in accordance with the current version of the following.

- **UK Regulations and Safety Standards or their European Norm Replacements.**
- **Building Regulations** (issued by the Department of the Environment).
- **Building Standards** (issued by the Scottish Development Department).
- **IEE Wiring Regulations.**
- **Electricity At Work Regulations.**

Before connecting the appliance, make sure that the supply voltage marked on the rating plate corresponds with your mains supply voltage.

WARNING: THIS APPLIANCE MUST BE EARTHED.

- This appliance should be wired into a 13A (16A for P639-BS/SS) double pole switched fused spur outlet, having 3 mm contact separation and placed in an easily accessible position adjacent to the appliance. The spur outlet must still be accessible even when your oven is located in its housing.

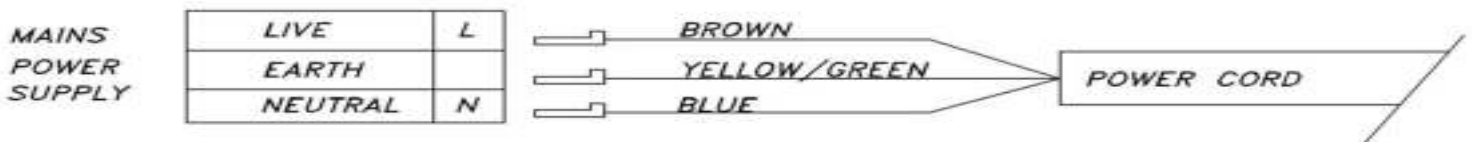

- To connect the oven power cord, loosen and remove the cover on the terminal block, in order to gain access to the contacts inside. Make the connection, securing the cord in place with the cable clamp provided and then immediately close the terminal block cover again.
- If you have to change the oven power cord, the earthing (yellow/green) conductor must always be 10 mm longer than the line conductors.
- Care must be taken to ensure that the temperature of the mains supply cable does not exceed 50°C.
- If the mains supply cable is damaged, then it must be replaced by an appropriate replacement which can be obtained from the Baumatic Spares Department.

Installing the oven into the kitchen cabinet

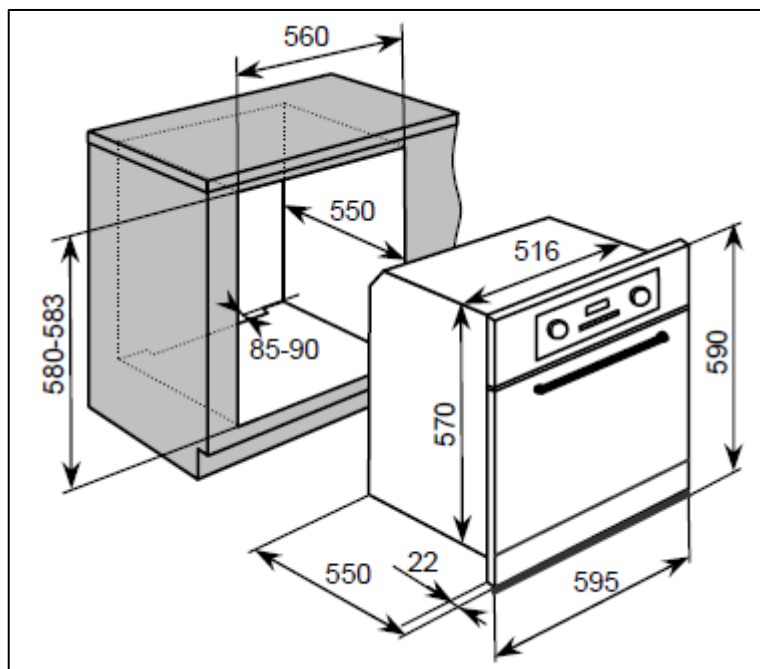

Positioning the appliance

- Ensure that the aperture that you will be fitting the oven into is of the size given in the above diagram.
- The oven must be fitted into an oven housing with the ventilation cut-outs shown in the “Ventilation requirements” section on the next page.
- Ensure that the rear panel of the furniture housing unit has been removed.

Ventilation requirements

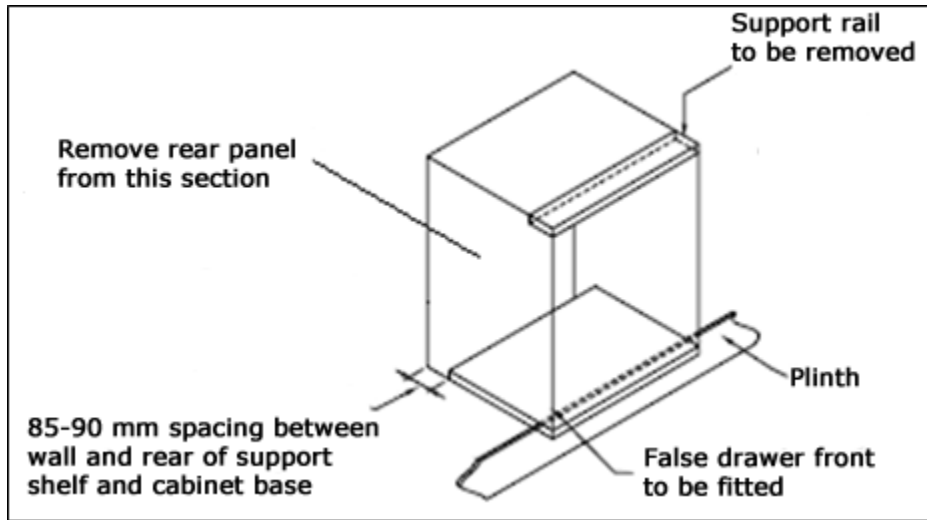

(Figure shows the ventilation and cut-out requirements for the installation of the appliance into a standard kitchen unit).

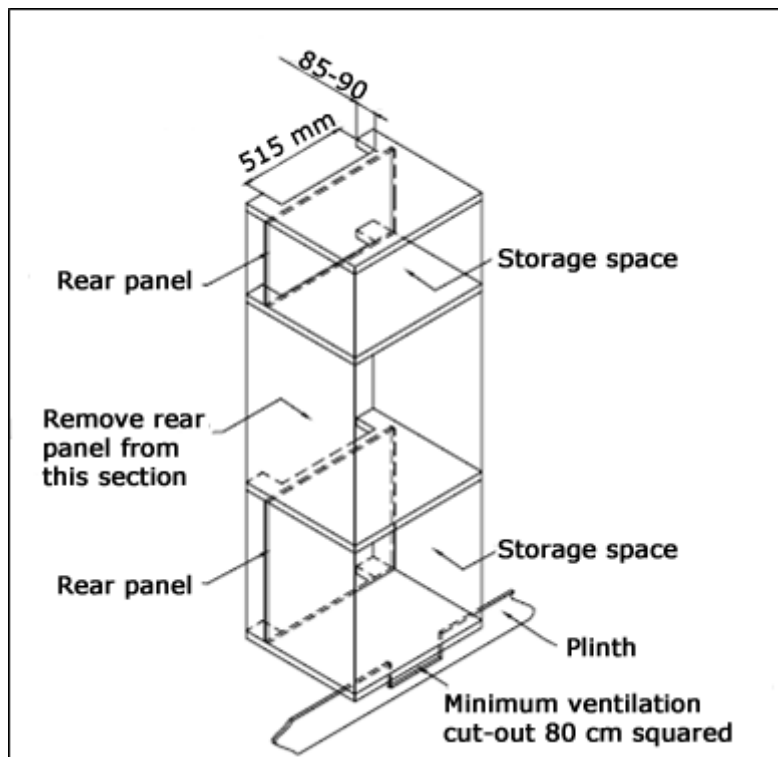

(Figure shows the ventilation and cut-out requirements for the installation of the appliance into a tall housing unit).

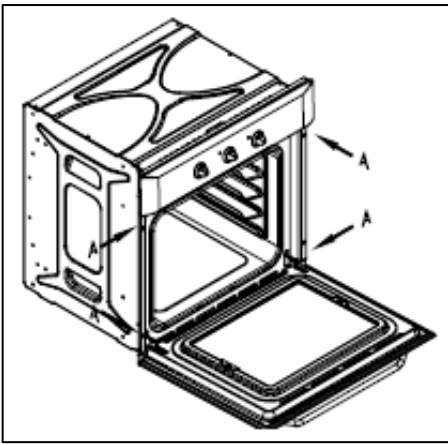

- Ensure that the oven has been securely fixed into the housing unit. The fixing of the oven into the housing is made by using four screws. These should be screwed through the oven cabinet and into the housing unit.

My appliance isn't working correctly

- ***The oven isn't coming on.***
 - * Check that the oven is in manual operation mode.
 - * Check that you have selected a cooking function and a cooking temperature.
- ***There appears to be no power to the oven and grill.***
 - * Check that the appliance has been connected to the electrical mains supply correctly.
 - * Check that the mains fuses are in working order.
 - * Check that the operating instructions for setting the time of day and putting the appliance into manual operation mode have been followed.
- ***The grill function works but the main oven does not.***
 - * Check that you have selected the correct cooking function.
- ***The grill and top oven element is not working, or cuts out for long periods of time during use.***
 - * Allow the oven to cool for approximately 2 hours. Once cool, check whether the appliance is again working properly.

- ***My food is not cooking properly.***
 - * Ensure that you are selecting the correct temperature and the correct cooking function for the food that you are cooking. It may be appropriate to adjust your cooking temperature by plus or minus 10°C, to achieve the best cooking results.

- ***My food is not cooking evenly.***
 - * Check that the oven has been installed correctly and is level.
 - * Check that the correct temperatures and shelf positions are being used.

- ***The oven light is not working.***
 - * Refer to the “Replacing the oven bulb” section.

- ***I am getting condensation in my oven.***
 - * Steam and condensation is a natural by product of cooking any food with high water content, such as frozen food, chicken etc.
 - * You may get condensation in the oven cavity and forming between the oven door glasses. This is not necessarily a sign that the oven is not working correctly.
 - * Do not leave food in the oven to cool after it has been cooked and the oven has been switched off.
 - * Use a covered container, where practical, when cooking to reduce the amount of condensation that forms.



IMPORTANT: If your appliance appears not to be operating correctly, then you should disconnect it from your mains supply and then contact Baumatic Customer Care on telephone number (0118) 933 6911.

DO NOT ATTEMPT TO REPAIR THE APPLIANCE YOURSELF.

Please note that if an engineer is asked to attend whilst the product is under guarantee and finds that the problem is not the result of an appliance fault, then you may be liable for the cost of the call out charge.

The appliance must be accessible for the engineer to perform any necessary repair. If your appliance is installed in such a way that an engineer is concerned that damage will be caused to the appliance or your kitchen, then they will not complete a repair.

This includes situations where appliances have been tiled in, sealed in with sealant, have wooden obstructions placed in front of the appliance, like plinths. Or any installation other than the one specified by Baumatic Ltd. has been completed.

Please refer to the conditions of guarantee that appear on the warranty card that you receive with the appliance.

IMPORTANT: Baumatic Ltd. operates a policy of continuous improvement and reserves the right to adjust and modify its products without prior notification.

Baumatic Consumables

- **BC001** Degreaser for Dishwashers (200 g)
- **BC002** Descaler for Washing Machines and Dishwashers (200 g)
- **BC003** Ceramic Hob Cleaner (250 ml)
- **BC004** Oven Cleaner (250 ml)
- **BC005** Stainless Steel Cleaner and Protector (250 ml)
- **BC007** E-Cloth – General Purpose Cloth
- **BC008** Microwave Cover

To order a Baumatic consumable product please call 0123 5437 244 and quote the product code. You can also order online from eshop.baumatic.co.uk



United Kingdom

Baumatic Ltd.,
Baumatic Buildings,
6 Bennet Road,
Reading, Berkshire
RG2 0QX
United Kingdom

Sales Telephone

(0118) 933 6900

Sales Fax

(0118) 931 0035

Customer Care Telephone

(0118) 933 6911

Customer Care Fax

(0118) 986 9124

Spares Telephone

(01235) 437244

Advice Line Telephone

(0118) 933 6933

E-mail:

sales@baumatic.co.uk
customercare@baumatic.co.uk
spares@baumatic.co.uk
technical@baumatic.co.uk

Website:

www.baumatic.co.uk

Facebook:

www.facebook.com/baumatic.uk

Republic of Ireland

Service Telephone

1-890 812 724

Spares Telephone

091 756 771

Czech Republic/ Slovakia

Baumatic s.r.o.

Lípová 665/1
460 01 Liberec 4
Czech Republic

Panenská 34

811 03 Bratislava - Staré Mesto
Slovakia

+ 420 483 577 200 (CZ)

+ 421 255 640 618 (SK)

www.baumatic.cz

www.baumatic.sk

Germany

Kundendienst & Ersatzteile

Deutschland 0049(0)180-5888975

Oesterreich + 43 (0) 820 / 420423

www.baumatic.de

Italy

Baumatic Italia S.R.L.

Via Galvani N.3

35011 Campodarsego (PD)

+ 3904 9920 2297

www.baumatic.it

Holland

Baumatic Benelux B.V.

Dukdalfweg 15d

1332 BH ALMERE

Nederland

+ 31(0)36 549 1553 / 1555

www.baumatic.nl

